

Line pressure regulator LT2000

spectro**tec**



Line pressure regulator
LT2000-40-10-NFG



Line pressure regulator
LT2000-300-25-NFG

Product features

- Ergonomically designed line pressure regulator
- For non-corrosive technical gases
- Single-stage type with high control accuracy
- Central filter in the regulator
- Safety pressure gauges acc. to DIN EN ISO 5171
- Compact design
- Models for inlet pressure up to 300 bar available
- Pressure regulator with integrated relief valve (for inlet pressure > 40 bar)
- Piston type regulators for outlet pressure values of up to 50, 100 or 200 bar available

Technical data

Type	single-stage
Inlet pressure P₁	max. 40 / 300 bar
Outlet pressure P₂	for P ₁ ≤ 40 bar: 1.5 / 4 / 10 bar for P ₁ > 40 bar: 10 / 25 / 50 / 100 / 200 bar

Materials

Body, bonnet:	Brass
Diaphragm regulator:	EPDM
Valve seat regulator:	PA

Connectors

In- / outlet:	1/4"-NPT female
Outlet relief valve (P ₁ >40 bar):	1/8"-NPT female

Temperature range -30°C to +60°C

Leak rate <10⁻³ mbar l/s He

Weight for P₂ ≤ 20 bar: approx. 1.3 kg
for P₂ > 20 bar: approx. 1.5 kg

Flow rates pressure regulators LT2000:

Oxygen Inlet press. (P ₁) [bar]	Flow rate (Vn) [m ³ /h] at outlet press. (P ₂) [bar]			
	1	2,5	4	10
40	15	30	40	50
20	15	20	25	30
10	15	15	15	--
5	10	10	10	--

The flow rates for other pressure values can be found in the data sheet
Performance diagram.
Performance factor of
LT2000: L₁₀ = 3

For other gas types the flow rate must be multiplied with these factors:

Nitrogen	1.05
Hydrogen	4.00
Argon	0.90
Carbon dioxide	0.85
Helium	2.83

Line pressure regulator LT2000

Dimensions

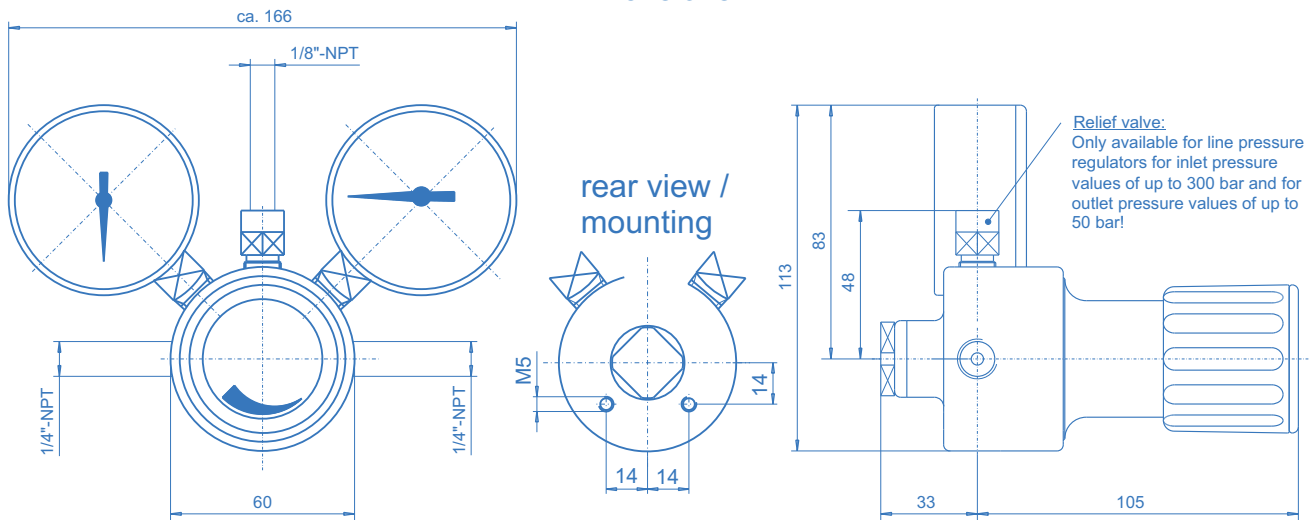

Example: LT2000 - 200 - 50 - NFG

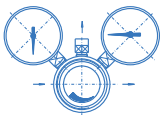

Ordering information:
Line pressure regulators LT2000

LT2000 - 300 - 50 - NFG

Inlet pressure P_1

40 - max. 40 bar
300 - max. 300 bar

Outlet pressure P_2

1,5 - max. 1,5 bar
(only for $P_1 \leq 40$ bar available)
4 - max. 4 bar
(only for $P_1 \leq 40$ bar available)
10 - max. 10 bar
25 - max. 25 bar (T-bar instead of hand wheel for $P_1 > 40$ bar)
50 - max. 50 bar (piston)
100 - max. 100 bar (piston)
200 - max. 200 bar (piston, not for oxygen!)

Gas type

NFG - non flammable gases
FG - flammable gases
 O_2 - oxygen

Specifications

- SPECTROTEC - components guarantee maximum quality by using high grade materials and a quality assurance program acc. to DIN ISO 9001
- All components which come into contact with the medium are cleaned free of oil and grease before the assembly.
- SPECTROTEC - components undergo a 100% leak- and function test

Applications

- For all gases compatible with the materials used in the products, e.g. compressed air, oxygen, nitrogen, carbon dioxide, forming gas, hydrogen, methane and rare gases

Important note regarding component selection

- A shut-off valve should be fitted into the supply line to the pressure regulator in such a way that the pressure gauges can be observed when the valve is opened.
- A shut-off valve in the piping between the pressure regulator and the tapping point is required if there is no means of shutting off the line at the tapping point or if the tapping point is a long way away from the pressure regulator. The piping must be designed to withstand the maximum line pressure.
- The downstream pipework must be designed for at least 20% above the max. regulator outlet pressure; a pressure in this range is required to open the relief valve.